



PRESS RELEASE

Oggetto: PRODUCTON NEWS

2012 Chassis Range presented

Among the new products, a 32mm tubing chassis, new braking systems, accessories and great bodywork innovation

Birel's 2012 chassis range, named S4, presents two models reserved to top classes: RY 30-S4 made with 30mm tubes and RY 32-S4 made with 32mm tubes.

Both models will have a version for KF (and single-gear in general) classes and one for KZ with gear;

at this regard it must be said that the 30mm tubing model is more suitable for KF categories, while the RY 32-S4 chassis has been developed, with excellent performances, more specifically for KZ.

Birel chassis selection will be completed by model C-28-R for MINI and Cadet classes.

As customary, all Racing chassis manufactured by the Lissone-based company are the product of the knowhow of the in-house racing division (Birel Motorsport), which guarantees a level of quality among the best worldwide for standard items.

As a matter of fact, all new ideas involving the 2012 line have undergone racing testing and combine top performance and reliability.

As already said, the new features include the innovative 32mm tubing model (RY32 - S4, CIK-FIA certified for 2012-2017), extensively developed throughout last season's top competitions and now ready to complete Birel's high segment offer.

This model relies on outstanding balance and great performance, matched to easy tuning, one of Birel's outstanding strong points.

Still innovation wise, we have to highlight the great job carried out on model RY 30, with structural evolution involving the front, for karts which are more precise and easier to drive.

Also the junior class C 28-R model has been enhanced, transforming the bodywork to achieve better grip and balance. Bodywork designed for KF and KZ classes now also features a smaller new axle bearing support, with three height adjustment options.

Whereas, the accessory side is packed with brand new ideas for the braking systems, both KF and KZ, with backlash gear and cast iron floating discs.

Still in the accessory department, new side fairings (optional and available from January 2012 on) for racing chassis, lighter and more aerodynamic, able to improve balance and achieve even smoother driving.





NOVELTIES BIREL KARTS 2012:

- ❖ **Rear brake system mod. RR I-25** : (see drawing) with self adjusting braking at 4 pistons. With floating cast iron brake disc diam. 180mm and connection to the axle bearing by a radial support.

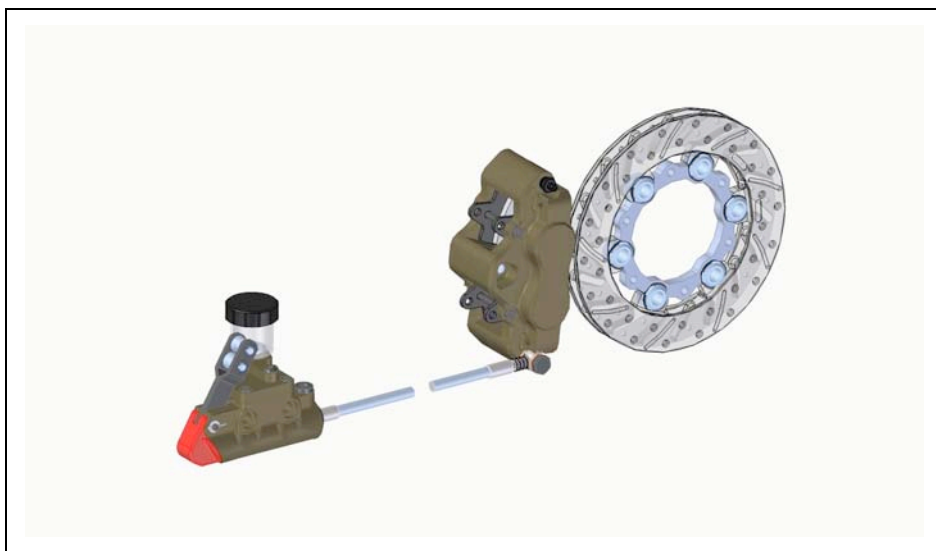

- ❖ **Front brake system KZ mod. RR I-25**: (see drawing) with self adjusting braking at 2 pistons and with fix cast iron brake disc diam. 150mm

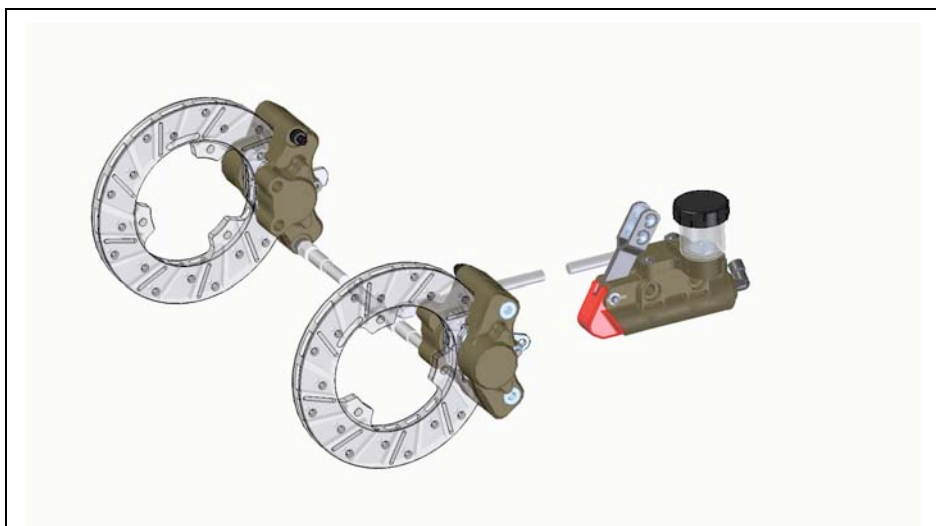



- ❖ **Front manual brake system mod. RR I-25:** (see drawing) with self adjusting braking and with floating steel brake disc diam. 150mm.

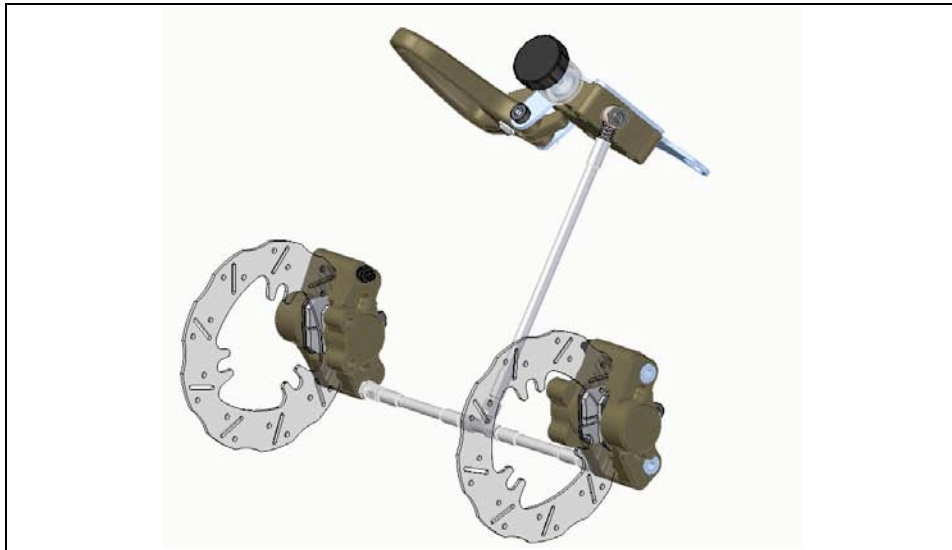

- ❖ **Support axle bearing:** (see drawing) it has been reduced and there is the possibility of height in three different position.

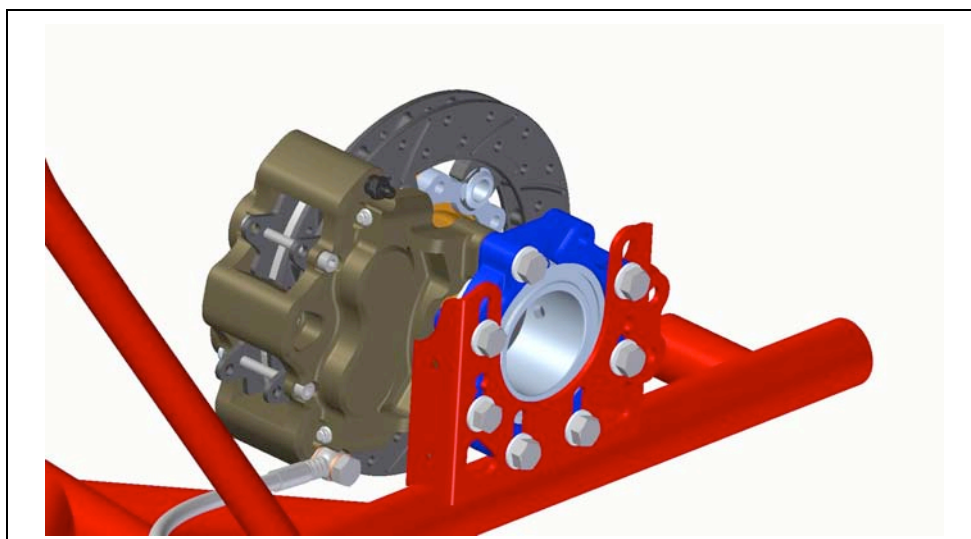



- ❖ **Petrol tank:** it has been relocated further down with consequent change of the floor panel that will be flat, leaving a greater adjustment of the position of the steering wheel (up/down).



- ❖ **Frame :** in order to improve accuracy of the forecarriage, structural changes had been made to the frame especially in the front. That resulting in improved performance, easier driving and the constancy of the kart
- ❖ **Side pods:** new side pods had been developed for the “racing” karts. They will be lighter and aerodynamics to further improve the balance and the easier driving of the kart. These pods will be available as Optional from January 2012.

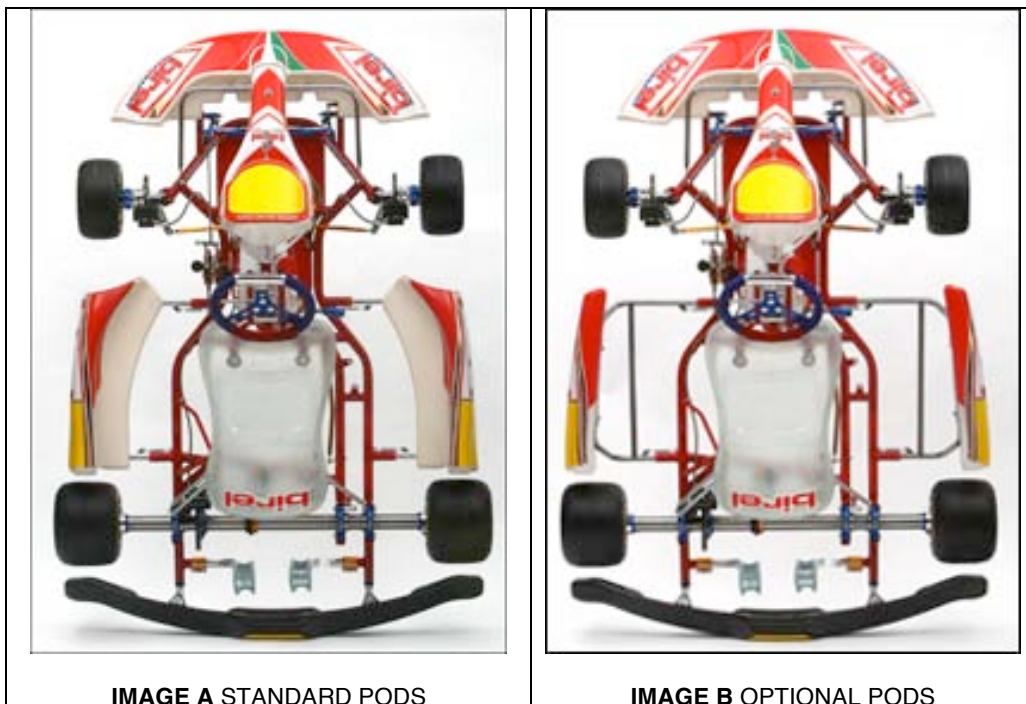

IMAGE A STANDARD PODS

IMAGE B OPTIONAL PODS